

SOLE
FITNESS

OWNER'S MANUAL
Model: 16008300650
F65 Treadmill

Please carefully read this entire manual
before operating your new treadmill.

ATTENTION: Before returning your SOLE product to any retailer, or if you require any assistance with assembly or technical support please call us first for assistance at 1-888-707-1880. Thank you for your SOLE purchase.

TABLE OF CONTENTS

<u>Product Registration</u>	1
<u>Important Safety Instructions</u>	2
<u>Important Electrical Instructions</u>	3
<u>Important Operation Instructions</u>	4
<u>Assembly instructions</u>	8
<u>Folding Instructions</u>	12
<u>Transport Instructions</u>	12
<u>Operation of Your New Treadmill</u>	13
<u>Bluetooth® Connectivity</u>	17
<u>Charging Function</u>	18
<u>Programmable Features</u>	19
<u>General Maintenance</u>	25
<u>Service Checklist - Diagnosis Guide</u>	28
<u>Exploded View Diagram</u>	30
<u>Parts List</u>	31
<u>Manufacturer's Limited Warranty</u>	35

SOLE

FITNESS

CONGRATULATIONS ON YOUR NEW TREADMILL AND WELCOME TO THE SOLE FAMILY!

Thank you for your purchase of this quality treadmill from Dyaco Canada Inc. Your new treadmill has been manufactured by one of the leading fitness manufacturers in the world and is backed by one of the most comprehensive warranties available. Dyaco Canada Inc. will do all we can to make your ownership experience as pleasant as possible for many years to come.

If you have any questions about your new Sole product or questions about the warranty, contact Dyaco Canada Inc. at 1-888-707-1880.

Please take a moment at this time to record below the name of the dealer, their telephone number and the date of purchase for easy contact in the future. We appreciate your confidence in **SOLE** and we will always remember that you are the reason we are in business. Please go to www.dyaco.ca/warranty and complete the online warranty registration.

Yours in Health,
Dyaco Canada Inc.

Name of Dealer: _____

Telephone Number of Dealer: _____

Purchase Date: _____

PRODUCT REGISTRATION

RECORD YOUR SERIAL NUMBER

Please record the Serial Number of this fitness product in the space provided below.

Serial Number _____



REGISTER YOUR PURCHASE

Please visit us at www.dyaco.ca/warranty to register your purchase.

IMPORTANT SAFETY INSTRUCTIONS

WARNING - Read all instructions before using this exercise equipment.

DANGER - To reduce the risk of electric shock disconnect your SOLE treadmill from the electrical outlet prior to cleaning and/or service work.

WARNING - To reduce the risk of burns, fire, electric shock, or injury to persons, install the treadmill on a flat level surface with access to a 110-volt, 15-amp grounded outlet with only the treadmill plugged into the circuit.

DO NOT USE AN EXTENSION CORD UNLESS IT IS A 14AWG OR BETTER, WITH ONLY ONE OUTLET ON THE END: DO NOT ATTEMPT TO DISABLE THE GROUNDED PLUG BY USING IMPROPER ADAPTERS, OR IN ANY WAY MODIFY THE CORD SET.

A serious shock or fire hazard may result in computer malfunctions. See Grounding Instructions, page 3.

- Do not operate the treadmill on deeply padded, plush or shag carpet. Damage to both carpet and treadmill may result.
- Do not block the rear of the treadmill. Provide a minimum of 3 1/2 feet clearance between the rear of the treadmill and any fixed object.
- Keep children under the age of 13 away from this machine. There are obvious pinch points and other caution areas that can cause harm.
- Keep hands away from all moving parts.
- Never operate the treadmill if it has a damaged cord or plug. If the treadmill is not working properly, call your dealer.
- Keep the cord away from heated surfaces.
- Do not operate where aerosol spray products are being used or where oxygen is being administered. Sparks from the motor may ignite a highly gaseous environment.
- Never drop or insert any object into any openings.
- Do not use outdoors.
- To disconnect, turn all controls to the off position, remove tether cord, then remove the plug from the outlet.
- Do not attempt to use your treadmill for any purpose other than for the purpose it is intended.
- The pulse sensors are not medical devices. Various factors, including the user's movement, may affect the accuracy of heart rate readings. The pulse sensors are intended only as exercise aids in determining heart rate trends in general.
- Use the handrails provided; they are for your safety.
- Wear proper shoes. High heels, dress shoes, sandals or bare feet are not suitable for use on your treadmill. Quality athletic shoes are recommended to avoid leg fatigue.
- This exercise equipment is not intended for use by persons with reduced physical, sensory or mental capabilities, or lack of experience and knowledge unless they have been given supervision or instruction concerning use of the exercise equipment by a person responsible for their safety.

Remove tether cord after use to prevent unauthorized treadmill operation.

SAVE THESE INSTRUCTIONS - THINK SAFETY!

IMPORTANT ELECTRICAL INSTRUCTIONS

WARNING!

Route the power cord away from any moving part of the treadmill including the elevation mechanism and transport wheels.

NEVER remove any cover without first disconnecting AC power.

If voltage varies by ten percent (10%) or more, the performance of your treadmill may be affected. Such conditions are not covered under your warranty. If you suspect the voltage is low, contact your local power company or a licensed electrician for proper testing.

NEVER expose this treadmill to rain or moisture. This product is NOT designed for use outdoors, near a pool or spa, or in any other high-humidity environment. The maximum operating temperature specification is 40 degrees C, and humidity is 95% non-condensing (no water drops forming on surfaces).

Circuit breakers: Avoid AFCI/GFCI circuit breakers if possible. These breakers may trip occasionally during exercise because of the high inrush currents of the treadmill drive electronics and motor. This is an issue that affects all treadmill brands.

New laws in your area may require these breakers. If you do have these breakers and outlets in your home and are experiencing nuisance tripping, you should check if there are any other devices plugged into the same circuit. Some examples of devices that may also cause tripping are fluorescent lights with electronic ballasts, coffee maker, space heater, hair drier. Optimally the treadmill should be the only device plugged into the circuit.

Our treadmills have surge suppressors built in to help avoid nuisance tripping. We have tested several AFCI/GFCI breakers and outlets with our products. Brands we have tested are: Eaton (Cutler Hammer Series), Leviton (Smart lock pro) and Schneider Electric (Canadian home series). These breakers do not trip in our testing, when connected to our treadmills, as long as no other devices are plugged into the same circuit.

GROUNDING INSTRUCTIONS

This product must be grounded. If the treadmill should malfunction or breakdown, grounding provides a path of least resistance for electric current, reducing the risk of electric shock. This product is equipped with a cord having an equipment-grounding plug. The plug must be plugged into an appropriate outlet that is properly installed and grounded in accordance with all local codes and ordinances.

DANGER - Improper connection of the equipment-grounding conductor can result in a risk of electric shock. Check with a qualified electrician or serviceman if you are in doubt as to whether the product is properly grounded. Do not modify the plug provided with the product if it will not fit the outlet; have a proper outlet installed by a qualified electrician.

This product is for use on a nominal 110-volt circuit, and has a grounding plug that looks like the plug illustrated below. A temporary adapter that looks like the adapter illustrated below may be used to connect this plug to a 2-pole receptacle as shown below if a properly grounded outlet is not available. The temporary adapter should be used only until a properly grounded outlet, (shown below) can be installed by a qualified electrician. The green colored rigid ear-lug, or the like, extending from the adapter, must be connected to a permanent ground such as a properly grounded outlet box cover. Whenever the adapter is used, it must be held in place by a metal screw.

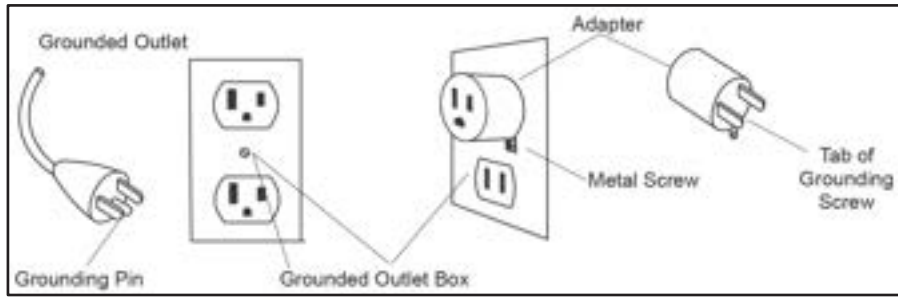

IMPORTANT OPERATION INSTRUCTIONS

- **NEVER** operate this treadmill without reading and completely understanding the results of any operational change you request from the computer.
- Understand that changes in speed and incline do not occur immediately. Set your desired speed on the computer console and release the adjustment key. The computer will obey the command gradually.
- **NEVER** use your treadmill during an electrical storm. Surges may occur in your household power supply that could damage treadmill components. Unplug the treadmill during an electrical storm as a precaution.
- Use caution while participating in other activities while walking on your treadmill; such as watching television, reading, etc. These distractions may cause you to lose balance or stray from walking in the center of the belt; which may result in serious injury.
- **NEVER** mount or dismount the treadmill while the belt is moving. **SOLE** treadmills start at a very low speed and it is unnecessary to straddle the belt during start-up. Simply standing on the belt during slow acceleration is proper after you have learned to operate the unit.
- Always hold on to a handrail or hand bar while making control changes (incline, speed, etc.).
- Do not use excessive pressure on the console control keys. They are precision set to function properly with little finger pressure. Pushing harder is not going to make the unit go faster or slower. If you feel the buttons are not functioning properly with normal pressure contact your **SOLE** dealer.

IMPORTANT SAFETY INSTRUCTIONS

A safety tether cord is provided with this unit and should be used at all times. It is for your safety should you fall or move too far back on the tread-belt. Pulling this safety tether cord will stop tread-belt movement.

To Use:

1. Place the safety key into position on the console control head. Your treadmill will not start and operate without this. Removing the safety key also secures the treadmill from unauthorized use.
2. Fasten the plastic clip onto your clothing securely to assure good holding power.
Note: *The clip should be attached securely to make certain it does not come off. Be familiar with its function and limitations. The treadmill will stop, depending on speed, with a one to two-step anytime the safety key is pulled off the console. Use the red **Stop** switch in normal operation.*
3. If the console displays "Safety key removed, the machine stopped. click Replace the key to Operate", put the Safety key back to continue using the treadmill.

IMPORTANT SAFETY INSTRUCTIONS

READ BEFORE UNPACKING YOUR FOLDING TREADMILL

Serious injury could occur if this folding treadmill is not unpacked properly.

A deck restraint shipping strap is installed around the treadmill base, preventing the treadmill from folding up accidentally during shipping. If the restraint strap is improperly removed, the treadmill could fold up unexpectedly and cause injury if someone is standing near the treadmill.

To ensure your personal safety during the removal of the shipping strap please make sure the treadmill is positioned flat on the ground, in the orientation it would be in if you were using the treadmill. Do not tilt the treadmill up on its side while removing the shipping strap: this could cause the treadmill’s folding mechanism to spring open. To remove the strap, pull up on the strap and cut it with a pair of scissors.

There is a safety pin locked on the treadmill base that prevents the treadmill from unfolding accidentally during shipping. This safety pin has to be removed before powering on or using the incline function to avoid any damage to the machine. When removing the safety pin, pull it away from the treadmill base completely.

PREVENTATIVE MAINTENANCE CHART

Vacuum Under Motor Cover & Check Wiring (Every Other Month)	Clean & Inspect Deck for Lubrication (Every Other Month)	Lubricate Deck (Every 90 hours or sooner if dry)	Inspect Belt Tracking (Monthly) Adjust if necessary	Date

F65 ASSEMBLY PACK CHECKLIST

2 HARDWARE STEP 2

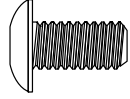

#130. 5/16" × 1/2"_
Button Head Socket Bolt
(8 pcs)

3 HARDWARE STEP 3



#113. Ø10 × 1.5T_
Split Washer (4pcs)

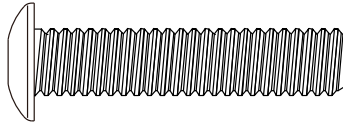

#139. 3/8" × 1-3/4"_
Button Head Socket Bolt
(4pcs)

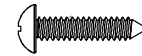

#175. 3.5 × 16m/m_
Sheet Metal Screw
(2pcs)

4 HARDWARE STEP 4



#137. M5 × 30m/m_
Phillips Head Screw
(4pcs)

5 HARDWARE STEP 5

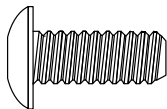

#159. 5/16" × 3/4"_
Button Head Socket Bolt
(4 pcs)

6 HARDWARE STEP 6



#175. 3.5 × 16m/m_
Sheet Metal Screw
(6 pcs)

7 HARDWARE STEP 7

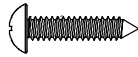

#175. 3.5 × 16m/m_
Sheet Metal Screw
(4 pcs)

8 HARDWARE STEP 8

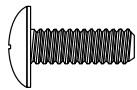

#128. M5 × 15m/m_
Phillips Head Screw
(4 pcs)

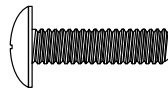

#95. M5 × 25m/m_
Phillips Head Screw
(2 pcs)

ASSEMBLY TOOLS

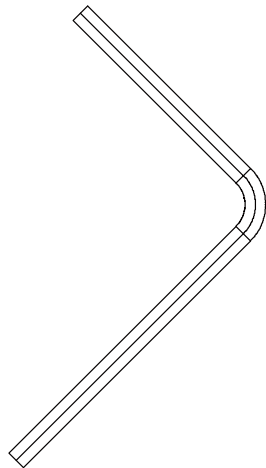

#132. M6 L Allen Wrench

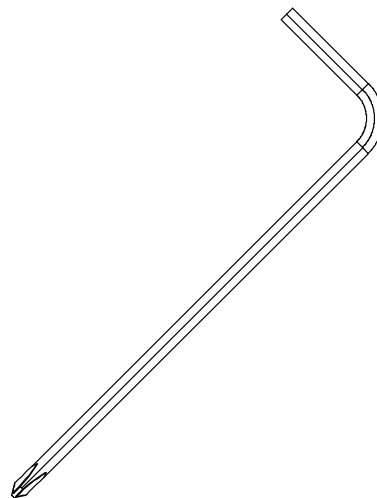

#131. Combination M5 Allen Wrench
& Phillips Head Screwdriver

F65 ASSEMBLY INSTRUCTIONS

1 ASSEMBLY STEP 1

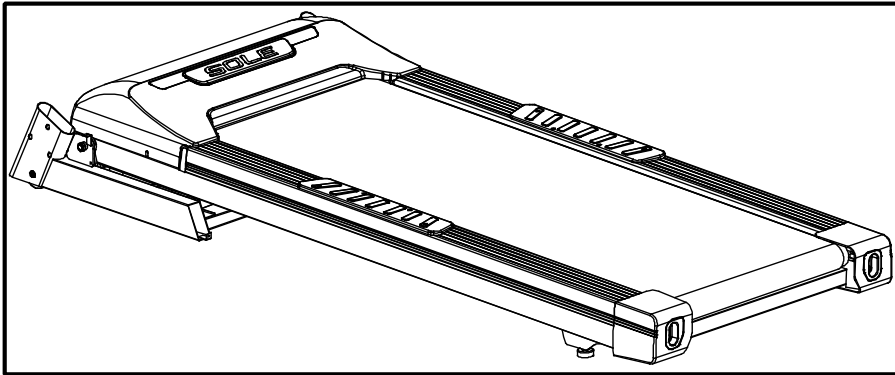

1. Remove the treadmill from the carton and position it aside on a smooth, levelled floor. The rear should be at least 3' from any wall. You must remove the plastic wrap and Styrofoam from beneath the unit before removing the Velcro belt. **Tilting the unit sideways after removing the belt may cause the unit to fold and bounce upwards. This can cause serious injury.**

2 ASSEMBLY STEP 2

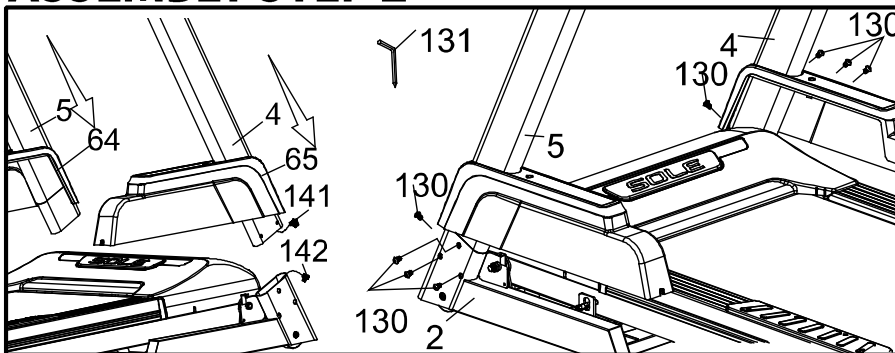

HARDWARE STEP 2

#130. 5/16" x 1/2" _
Button Head Socket Bolt
(8 pcs)

1. Insert Left Upright (5) through Frame Base Cover (L) (64) and insert Right Upright (4) through Frame Base Cover (R) (65) and connect 6P Computer Cable (Middle) (141) with 6P Computer Cable (Lower) (142).
2. Insert the Right and Left Uprights (4) and (5) into Frame Base (2) and then use M5 Allen Wrench Head Screw Wrench (131) to tighten 8 pcs of Button Head Socket Bolt (130).

NOTE: Please DON'T Tighten All Screws.

Before attaching the hardware in Step 3, make sure the cables you just connected don't get pinched in between the steel tubing. If they do, this may cause issues that prevent the treadmill from operating properly.

3

ASSEMBLY STEP 3

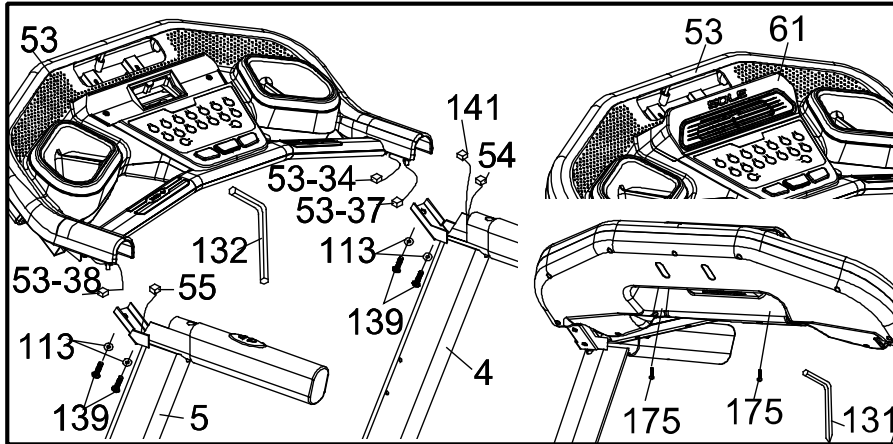

HARDWARE STEP 3

- #113. $\varnothing 10 \times 1.5T$ Split Washer (4pcs)
- #139. $3/8" \times 1-3/4"$ Button Head Socket Bolt (4pcs)
- #175. $3.5 \times 16m/m$ Sheet Metal Screw (2pcs)

1. Connect 6P Computer Cable (Middle) (141) with 6P Computer Cable (Upper) (53-34), connect Speed Adjustment Switch W/Cable (54) with Speed Cable (Upper) (53-37), and connect Incline Adjustment Switch W/Cable (55) with Incline Cable (Upper) (53-38) then insert console Assembly (Bottom) (53) into the Right and Left Uprights (4) and (5) and use L Allen Wrench (132) to tighten 4 pcs of Button Head Socket Bolt (139) and 4 pcs of Split Washer (113).
2. Install Fan Plate Assembly (61) on the Console Assembly Bottom (53) and use Allen Wrench Head Screw Wrench (131) to tighten 2 pcs of Sheet Metal Screw (175).

NOTE: Please DON'T Tighten All Screws.

4

ASSEMBLY STEP 4

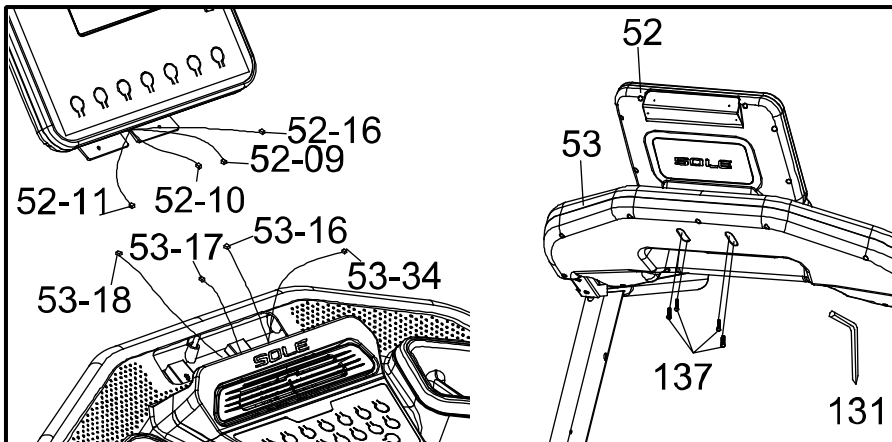

HARDWARE STEP 4

- #137. $M5 \times 30m/m$ Phillips Head Screw (4pcs)

1. Connect 11P Computer Cable (Upper) (52-09) with 11P Computer Cable (Lower) (53-16), and connect 4P Computer Cable (Upper) (52-10) with 4P Computer Cable (Lower) (53-17), and connect 9P Computer Cable (Upper) (52-11) with 9P Computer Cable (Lower) (53-18), and connect 6P Computer Cable (52-16) with 6P Computer Cable (Upper) (53-34). Place Console Assembly (Top) (52) to Console Assembly (Bottom) (53) and use Allen Wrench Head Screw Wrench (131) to tighten 4 pcs of Phillips Head Screw (137).

Before attaching the hardware in Step 4, make sure the cables you just connected don't get pinched in between the steel tubing. If they do, this may cause issues that prevent the treadmill from operating properly.

5 ASSEMBLY STEP 5

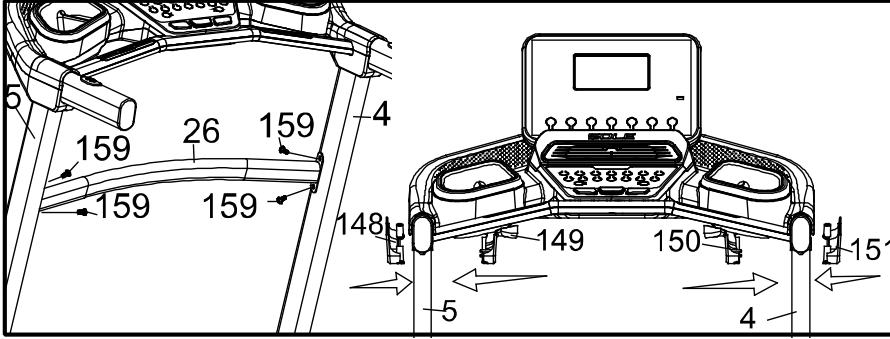

HARDWARE STEP 5

#159. 5/16" × 3/4" _
Button Head Socket Bolt
(4 pcs)

1. Install Handrail Support (26) between Left and Right Uprights (5) and (4) and use Allen Wrench Head Screw Wrench (131) to tighten 4 pcs of Button Head Socket Bolt (159).
2. Install Console Mast Cover Outer (L) (148), Console Mast Cover Inner (L) (149), Console Mast Cover Outer (R) (151) and Console Mast Cover Inner (R) (150) in Left and Right Uprights (5) and (4).

NOTE: Please Tighten All Screws After All Components Assembly is Complete.

6 ASSEMBLY STEP 6

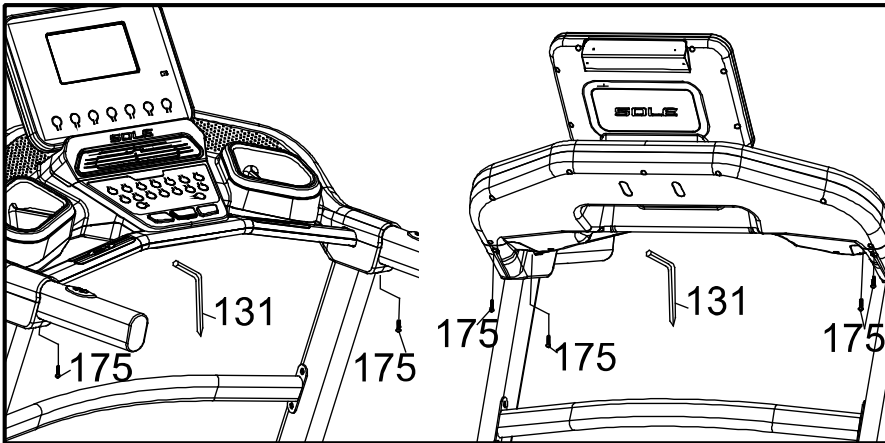

HARDWARE STEP 6

#175. 3.5 × 16m/m _
Sheet Metal Screw (6 pcs)

1. Allen Wrench Head Screw Wrench (131) to tighten 6 pcs of Sheet Metal Screw (175).

7 ASSEMBLY STEP 7

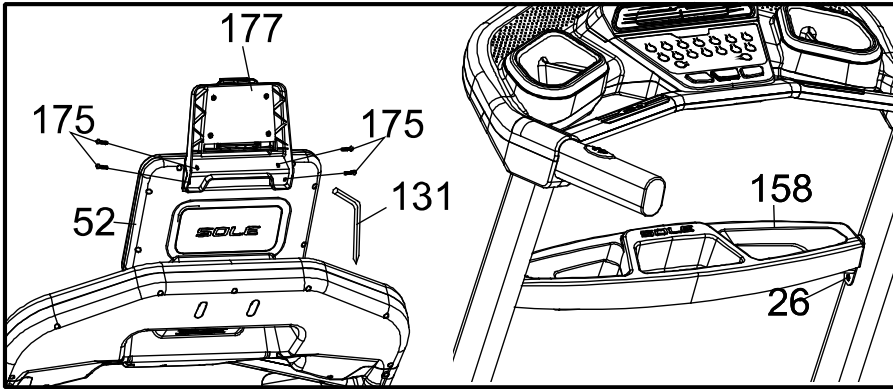

HARDWARE STEP 7

#175. 3.5 × 16m/m_
Sheet Metal Screw
(4 pcs)

1. Place Tablet Holder (177) on Console Assembly (Top) (52) and use M5_Allen Wrench Head Screw Wrench (131) to tighten 4 pcs of Sheet Metal Screw (175).
2. Install Beverage Holder (158) on Handrail Support (26).

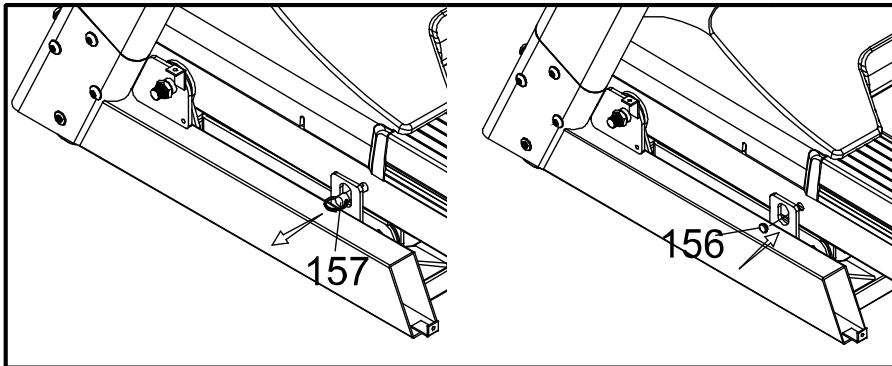

NOTE: After the above, please pull the locking pin (157) out and insert the End Cap (156) into the hole.

8 ASSEMBLY STEP 8

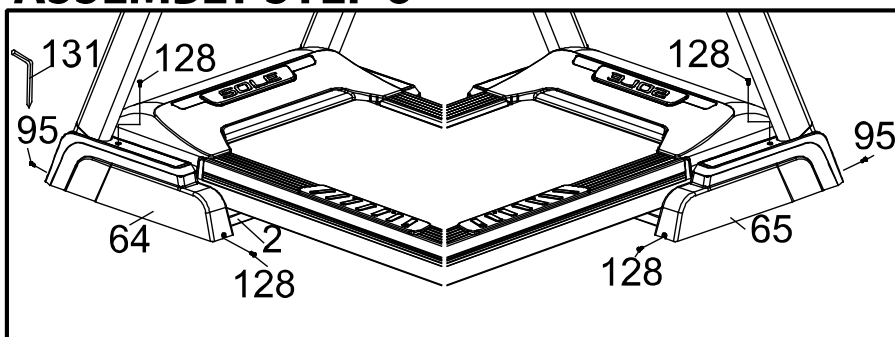

HARDWARE STEP 8

#95. M5 × 25m/m_
Phillips Head Screw
(2 pcs)
#128. M5 × 15m/m_
Phillips Head Screw
(4 pcs)

1. Install Frame Base Cover left (64) and right (65) in Left and Right Uprights (5) and (4) and use Allen Wrench Head Screw Wrench (131) to tighten 4 pcs of Phillips Head Screw (128) and 2 pcs of Phillips Head Screw (95) into Frame Base (2).

FOLDING INSTRUCTIONS

Do not attempt to move the unit unless it is in the folded and locked position. Be sure the power cord is secured to avoid possible damage. Use both handrails to maneuver the unit to the desired position.

■ TO FOLD THE TREADMILL

Make certain that the treadmill is at a minimum incline. Lift the treadmill's running deck until it is secured by the locking telescoping tube assembly in the center back of the base.



■ TO UNFOLD THE TREADMILL

Apply slight forward pressure* on the treadmill running deck with one hand. Pull down the unlocking lever and slowly lower the running deck to the floor. The deck will descend unassisted when it reaches about waist high.

■ *At the rear roller area to relieve pressure on the locking system.



TRANSPORTATION INSTRUCTIONS

The treadmill is equipped with transport wheels that are engaged when the treadmill is folded. After folding simply roll the treadmill away.

OPERATION OF YOUR TREADMILL

GETTING FAMILIAR WITH THE CONTROL PANEL

F65 CONSOLE



GETTING STARTED

Power the treadmill on by plugging it into an appropriate wall outlet, then turn on the power switch located at the front of the treadmill below the motor hood. Ensure that the **Safety Key** is installed, as the treadmill will not power on without it.



When the power is turned on, the message window displays the current version of the software. Then the **Time** and **Pace Windows** will display Odometer readings for a short time. **Time Window** will show how many hours the treadmill has been in use and the **Pace Window** will show how many miles (or Kilometers if the treadmill is set to metric readings) the treadmill has gone. The treadmill will then enter idle mode, which is the starting point for operation.

START OPERATION

1. Attach the **Safety Key** to wake the display up, if it's not already on.
2. Press the **Start** key to begin belt movement. Adjust to the desired speed using the **Speed ▲/▼** keys on either the console. You may also use the speed keys 2, 3, 4, 5, 7, 9 or 12 to adjust the speed.
3. To slow down the tread-belt, press and hold the **Speed ▼** key on the console to the desired speed. You may also press the speed adjust keys, 2 through 12.
4. To stop the tread-belt, press **Stop** key or pull away **Safety Key**.



PAUSE/STOP/RESET FEATURE

1. When the treadmill is running, the pause feature may be utilized by pressing the red **Stop** key once. This will slowly decelerate the tread-belt to a stop. The incline will go to zero percent. The **Time**, **Distance** and **Calorie** readings will hold while the unit is in the pause mode. After 5 minutes the display will reset and return to the start-up screen.
2. To resume your exercise, while in Pause mode, press the **Start** key. The speed and incline will return to their previous settings.
 - Pause is executed when the **Stop** button is pressed once. If the **Stop** button is pressed for the second time, the program will end, and a workout summary will be displayed. If the **Stop** button is pressed for the third time, the console will return to the idle mode (start-up) screen. If the **Stop** button is held down for more than 3 seconds, the console will reset.

INCLINE FEATURE

- Incline may be adjusted any time after belt movement.
- Press and hold the **Incline ▲/▼** keys on the console to achieve your desired level of effort. You may also choose a more rapid increase / decrease by selecting desired key, 1, 3, 5, 7, 9, 12 and 15, on the console (incline).
- The **Incline Window** display will indicate incline position as adjustments are made.



DOT MATRIX CENTRE DISPLAY

Eighteen columns of dots – each 8 units high – indicate each segment of a workout for the F65 and eighteen columns of dots – each 8 units high – indicate each segment of a workout. The dots are only to show an approximate level of effort in speed or incline. They do not necessarily indicate a specific value - only an approximate percent to compare levels of intensity. In operation, the speed/incline dot matrix window will build a profile “picture” as values are changed during a workout. When the word “Speed” is lit above the dot matrix, it indicates that the Speed profile is being displayed. When the word “Incline” is lit above the dot matrix, it indicates the Incline profile is being displayed.

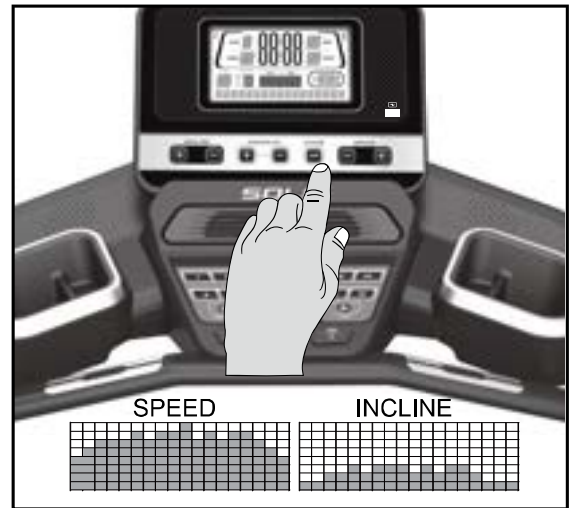

You may change the Dot Matrix profile view between Speed and Incline by pressing the **Enter** button. After pressing **Enter** to view the two profiles, pressing it for the third time will automatically alternate the Speed and Incline displays, showing each one for five seconds.

MESSAGE WINDOW DISPLAY

The **Message Window** will initially display **Program Name**. Each time the **Display** button is pressed, the next set of information will appear. The order of information displayed will be: **Program, Laps, Verticle, Segment Time, Max Speed** (in mph or km), and **Data Scan** mode. In **Data Scan** mode, the displayed information will change every 4 seconds in the **Message Window**.

1/4 MILE TRACK

The 1/4-mile track is displayed around the dot matrix window. The flashing dot indicates your progress. The number of laps you complete is accumulated in the lap counter, which is viewed in the **Message Window**.

CALORIE DISPLAY

Displays the cumulative calories burned at any given time during your workout.

Note: *This is only a rough guide used for comparison of different exercise sessions, which cannot be used for medical purposes.*

BACKLIGHT BRIGHTNESS ADJUSTMENT FUNCTION

LCD screen brightness adjustment operation mode:

1. In idle mode, press and hold the DISPLAY button for 5 seconds to enter the brightness adjustment function.
2. The LCD does not display all of them, only displays the moving string "BRIGHTNESS LEVEL" in the message bar and displays the number 1~10 in The Dot matrix.
3. Press SPEED+/- or INCLINE+/- button to adjust the brightness, adjust the number range 1~10.
4. Press ENTER to confirm and leave back to the IDLE MODE display.
5. Factory default: 10

PULSE FEATURE

The **Pulse (Heart Rate) Window** will display your current heart rate in beats per minute during the workout. You must use both stainless-steel sensors on the front crossbar to display your pulse or wear the wireless chest strap. The pulse value will display anytime the upper display is receiving a pulse signal.



TURNING OFF TREADMILL

1. The display will automatically turn off, by going into sleep, after 15 minutes of inactivity when in the Pause / Stop mode. Almost all power for the treadmill will be off except for some circuits that are needed to detect if any key is pressed, indicating the console should "wake up". When the console is "asleep" the treadmill draws very little power, for about as much as a television turned off.
2. Removing the **Safety Key** is similar to entering "sleep" mode. Turning off the main power switch in the front of the treadmill will completely remove any power.

****ATTENTION****

SLEEP MODE Your console comes in "Sleep mode" with different features by choice:

ON The unit goes energy-saving state after 15 minutes of inactivity.

OFF The console will stay lit while the power is on.

On LCD displays, press and hold the Stop, Enter, and Display keys for 5 seconds to turn ON or OFF the Sleep mode.

New Sole+ App to be used in conjunction with select Apple & Android devices!

In order to help you achieve your exercise goals, your new exercise machine comes equipped with a Bluetooth® transceiver that will allow it to interact with selected phones or tablet computers via the Sole + App.

Just download the free Sole + App from the Apple Store or Google Play, and then follow the instructions in the App to sync with your exercise machine.

You can press the "DISPLAY" button from the APP to view the display of the current workout data. When your exercise is complete press the APP "END & SAVE WORKOUT" to store the workout data.

The Sole + App also allows you to sync your workout data with one of many fitness cloud sites we support: Apple Health, Google Fit, Strava, MapMyFitness or Fitbit, with more to come.

Syncing the App with your exercise machine:

1. Download the App by scanning the QR code on the right.
2. Open the App on your device (phone or tablet) and make sure Bluetooth® is enabled on your device (phone or tablet).
3. In the App click the Bluetooth icon to search for your Sole + equipment (shown right). 
4. Under the Bluetooth scan result list, select the machine for connect. When the App and equipment are synced, the Bluetooth® icon on the equipment's console display will light up. Click "DISPLAY", you may now start using your Sole + App.
5. When your exercise is complete press the APP "END & SAVE WORKOUT" to store the workout data, and you will be prompted to sync your data with each available fitness cloud site. Please note you will have to download the applicable compatible fitness App, such as Apple Health, Google Fit, Strava, MapMyFitness or Fitbit, etc, in order for the icon to be active and available.

Note: Your device will need to be running on a minimum operating system of IOS 13.1 or Android 8.0 for the Sole + App to operate properly.

The exercise equipment can also play music wirelessly via Bluetooth. Turn on your mobile phone or tablet's Bluetooth function. Search for the name "Bt-speaker" in your device's Bluetooth menu. Tap to connect. Now your device can transmit music to the exercise equipment.

The exercise equipment's Bluetooth device (BLE 5.0) can also be connected to the Bluetooth wireless heart rate chest strap transmitter (BLE 5.0). The chest strap transmitter can receive signals even when the App is already in use. You can wear the Bluetooth wireless heart rate chest strap first then commence connection. While in connection, the console will show heart rate value via Bluetooth.

The icon  lights up when connecting to a Bluetooth heart rate chest strap successfully and the heart rate will then be displayed. The icon will be off if the Bluetooth heart rate chest strap is disconnected.



Charge Portable Devices with USB port

USB Port Charging function:

Charge your personal device during your workout using the fitness equipment's on-console USB port.

To charge your mobile electronics make sure the fitness equipment power is on.

Step 1: Connect your USB charging cable (not included) to the USB Power Port and to your device.

Step 2: Check to make sure your device icon indicates it is charging.



NOTE :

* USB charging cable is not included, make sure compatible USB charging cable is being used.

** Your device "charging" icon may or may not indicate it is charging. Depending on the amount of current your particular device requires for charging the icon may not be on but your device is still charging, but possibly at a lower charge rate.

***The USB port on the console is capable of powering USB devices. It provides up to **5Vdc/1.0** amp of power and meets USB 2.0 regulations. You will not be able to save your workout data to a USB via this port; it is used for charging purposes only.

PROGRAMMABLE FEATURES

The F65 have ten built-in programs: one Manual program, five preset profiles (**P1-P5**), two user defined programs (**U1 & U2**) and two Heart Rate programs (**HR1 & HR2**).

Hill

The **Hill** program simulates going up and down a hill. The workload will steadily increase and then decrease during the program.

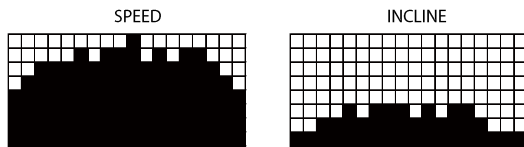

Fat Burn

The **Fat Burn** program is designed, as the name implies, to maximize the burning of fat. There are many schools of thought on the best way to burn fat but most experts agree that a lower exertion level that stays at a steady workload is the best. The absolute best way to burn fat is to keep your heart rate at around 60% to 70% of its maximum potential. This program does not use heart rate but simulates a lower, steady exertion workout.

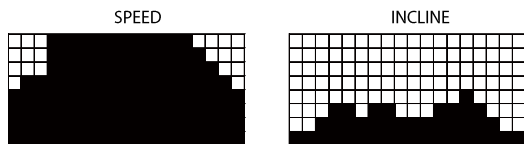

Cardio

The **Cardio** program is designed to increase your cardiovascular function and endurance. This is exercise for your heart and lungs. It will build up your heart muscle and increase blood flow and lung capacity. This is achieved by incorporating a higher level of exertion with slight fluctuations in work.

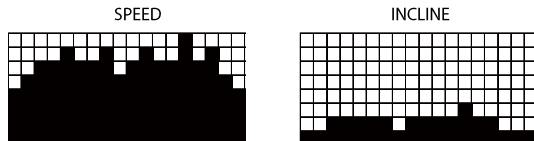

Strength

The **Strength** program is designed to increase muscular strength in your lower body. This program will steadily increase in workload to a high level and forces you to sustain it. This is designed to strengthen and tone your legs and glutes (muscles of the butt).

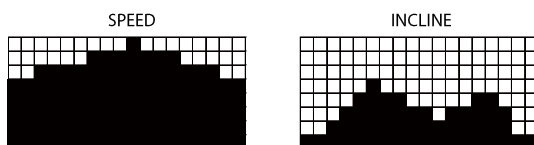

HIIT

The **HIIT** program takes you through high levels of intensity followed by periods of low intensity. This program increases your endurance by depleting your oxygen level followed by periods of recovery to replenish oxygen. Your cardiovascular system gets programmed to use oxygen more efficiently this way. This program also forces your body to become more efficient due to spikes in heart rate, between recovery periods. This aids in heart rate recovery from intense activities.

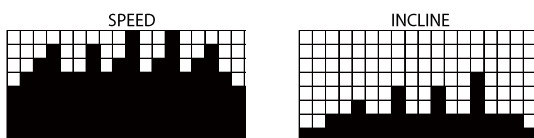

SELECTING A PROGRAM

1. Press the **Program ▲/▼** keys to view the programs on the screen then press the **Enter** key to select the program you would like to perform. The display will prompt you through the programming steps or you can just press the **Start** key to begin the program using the preset program values for age, weight and other program specific information.



2. If **Enter** was pressed, the **Message Window** will display **Age**. You may use any of the **▲/▼** keys to adjust your age. After adjusting press the **Enter** key.

Note: You may press **Start** at any time during the programming to start the program with the information you've already input.

3. The **Message Window** will now be displaying a value, which is your body weight. Entering the correct body weight will affect the calorie count. Use any of the **▲/▼** keys to adjust, then press **Enter**.

Calorie Display Note: No exercise machine can give you an exact calorie count because there are too many factors which determine exact calorie burn for a particular person. Even if someone is the exact same body weight, age and height, their calorie burn may be very different than yours. The **Calorie** display is to be used as a reference only to monitor improvement from workout to workout.

4. The **Time Window** and **Message Window** will now be displaying a value, which is total workout time desired. Use any of the **▲/▼** keys to adjust, and then press **Enter**. After adjusting, press the **Enter** key.
5. The **Message Window** will display the preset max speed of the selected program. Use any of the **▲/▼** keys to adjust, and then press **Enter**. Each program has various speed changes throughout; this allows you to limit the highest speed the program will reach at it's peak.
6. Press **Start** to begin the program. The program will begin with a 3 minute warm-up. If you want to bypass this and go directly to the beginning of the program, press **Start** again.

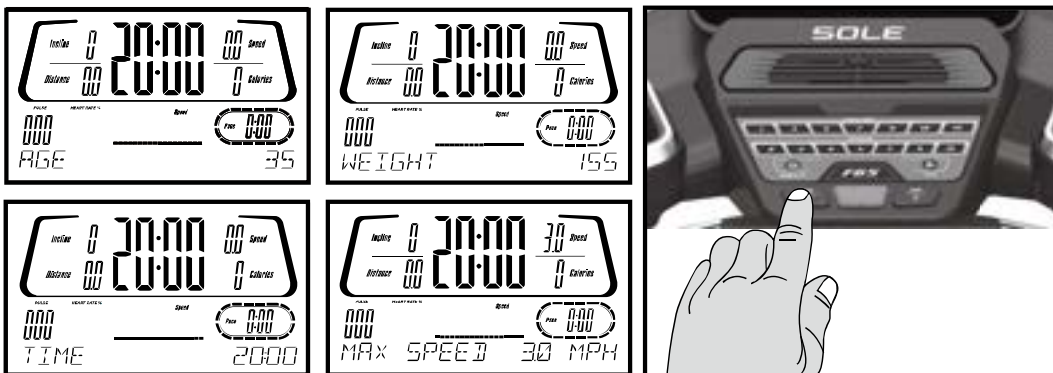

USER PROGRAMS

1. Select **User 1** or **User 2** via the **Program ▲/▼** keys then press **Enter**. Note that the dot matrix display portion will have a single row of dots at the bottom (Unless there is a previously stored program). If there is a program stored under the button that is pressed, it will be retrieved. If not, you have the option of programming in your first name. The **Message Window** will display and flash the letter "A". To change it, press the any **▲** key, then "B" will be displayed; if the any **▼** key is pressed, the letter "Z" will be displayed. After selecting the appropriate letter, press **Enter**. The letter "A" will again be displayed and blinking. Repeat the procedure until all letters of your first name are programmed (7 characters maximum). When your name is displayed, press **Stop** and it will be stored under either **User 1** or **User 2**.
2. Next the **Message Window** is flashing **Age**. Use the **Incline ▲/▼** keys to adjust. Press **Enter**. This is a must to continue even if age is not adjusted.
3. The **Message Window** will now be blinking a body weight value. Enter your body weight and press **Enter**.
4. The **Time Window** and **Message Window** will now be blinking a **Time** value. Adjust the **Time** and press **Enter**.
5. The first column (segment) will now be blinking. Using the **Speed ▲/▼** or keys, adjust the speed level to your desired effort for the first segment then press **Enter**. The second column will now be blinking. Repeat the above process until all segments have been programmed. The first column will be blinking again. This is for the incline programming. Repeat the above process to program all segments for incline.
6. Press the **Start** button to begin the workout and also save the program to memory.

Note: While in a User program, if you change the speed, all segment speeds from there on will also change.

Examples: If you increase your current speed 1 mph, the remaining segment speeds will increase by 1 mph. If you decrease your current speed .5 mph, the remaining segment speeds will decrease by .5 mph, etc.

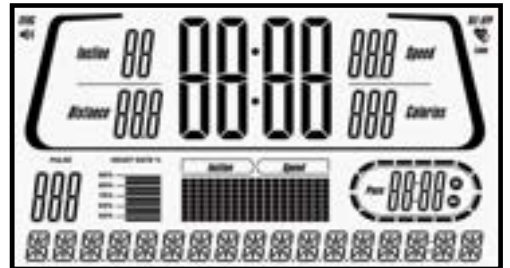

HEART RATE PROGRAMS

Before we get started, a word about Heart Rate:

The old motto, “no pain, no gain”, is a myth that has been overpowered by the benefits of exercising comfortably. A great deal of this success has been promoted by the use of heart rate monitors. With the proper use of a heart rate monitor, many people find that their usual choice of exercise intensity was either too high or too low and exercise is much more enjoyable by maintaining their heart rate in the desired benefit range.

To determine the benefit range in which you wish to train, you must first determine your Maximum Heart Rate. This can be accomplished by using the following formula: 220 minus your age. This will give you the Maximum Heart Rate (MHR) for someone of your age. To determine the effective heart rate range for specific goals you simply calculate a percentage your MHR. Your Heart rate training zone is 50% to 90% of your maximum heart rate. 60% of your MHR is the zone that burns fat while 80% is for strengthening the cardiovascular system. This 60% to 80% is the zone to stay in for maximum benefit.

For someone who is 40 years old their target heart rate zone is calculated:

$$\begin{aligned} 220 - 40 &= 180 \text{ (maximum heart rate)} \\ 180 \times .6 &= 108 \text{ beats per minute} \\ &\text{(60\% of maximum)} \\ 180 \times .8 &= 144 \text{ beats per minute} \\ &\text{(80\% of maximum)} \end{aligned}$$

So for a 40 year old the training zone would be 108 to 144 beats per minute.

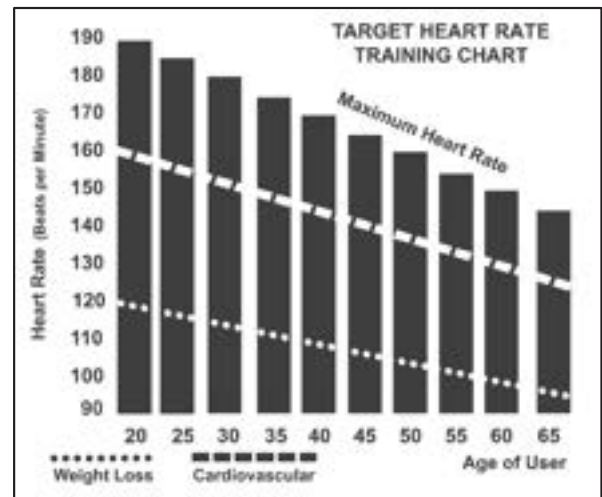

If you enter your age during programming the console will perform this calculation automatically. Entering your age is used for the Heart Rate programs. After calculating your MHR you can decide upon which goal you would like to pursue.

The two most popular reasons for, or goals, of exercise are cardiovascular fitness (training for the heart and lungs) and weight control. The black columns on the chart above represent the MHR for a person whose age is listed at the bottom of each column. The training heart rate, for either cardiovascular fitness or weight loss, is represented by two different lines that cut diagonally through the chart. A definition of the lines' goal is in the bottom left-hand corner of the chart. If your goal is cardiovascular fitness or if it is weight loss, it can be achieved by training at 80% or 60%, respectively, of your MHR on a schedule approved by your physician. Consult your physician before participating in any exercise program.

RATE OF PERCEIVED EXERTION

Heart rate is important but listening to your body also has a lot of advantages. There are more variables involved in how hard you should work out than just heart rate. Your stress level, physical health, emotional health, temperature, humidity, the time of day, the last time you ate and what you ate, all contribute to the intensity at which you should workout. If you listen to your body, it will tell you all of these things.

The rate of perceived exertion (RPE), also known as the Borg scale, was developed by Swedish physiologist G.A.V. Borg. This scale rates exercise intensity from 6 to 20 depending upon how you feel or the perception of your effort.

The scale is as follows:

Rating Perception of Effort

- 6 Minimal
- 7 Very,very light
- 8 Very,very light +
- 9 Very light
- 10 Very light +
- 11 Fairly light
- 12 Comfortable
- 13 Somewhat hard
- 14 Somewhat hard +
- 15 Hard
- 16 Hard +
- 17 Very hard
- 18 Very hard +
- 19 Very,very hard
- 20 Maximal

You can get an approximate heart rate level for each rating by simply adding a zero to each rating. For example, a rating of 12 will result in an approximate heart rate of 120 beats per minute. Your RPE will vary depending on the factors discussed earlier. That is the major benefit of this type of training. If your body is strong and rested, you will feel strong, and your pace will feel easier. When your body is in this condition, you are able to train harder and the RPE will support this. If you are feeling tired and sluggish, it is because your body needs a break. In this condition, your pace will feel harder. Again, this will show up in your RPE and you will train at the proper level for that day.

USING HEART RATE TRANSMITTER (OPTIONAL)

How to wear your wireless chest strap transmitter:

1. Attach the transmitter to the elastic strap using the locking parts.
2. Adjust the strap as tightly as possible as long as the strap is not too tight to remain comfortable.
3. Position the transmitter with the SOLE logo centered in the middle of your body facing away from your chest (some people must position the transmitter slightly left of center). Attach the final end of the elastic strap by inserting the round end and, using the locking parts, secure the transmitter and strap around your chest.
4. Position the transmitter immediately below the pectoral muscles.
5. Sweat is the best conductor to measure very minute heartbeat electrical signals. However, plain water can also be used to pre-wet the electrodes (2 ribbed oval areas on the reverse side of the belt and both sides of the transmitter). It's also recommended that you wear the transmitter strap a few minutes before your workout. Some users, because of body chemistry, have a more difficult time in achieving a strong, steady signal at the beginning. After "warming up", this problem lessens. As noted, wearing clothing over the transmitter/strap doesn't affect performance.
6. Your workout must be within range - distance between transmitter/receiver - to achieve a strong steady signal. The length of range may vary somewhat but generally stay close enough to the console to maintain good, strong, reliable readings. Wearing the transmitter immediately against bare skin assures you of proper operation. If you wish, you may wear the transmitter over a shirt. To do so, moisten the areas of the shirt that the electrodes will rest upon.

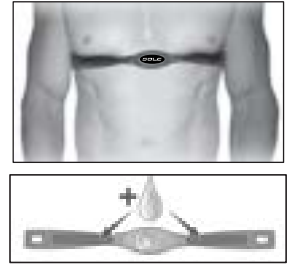

Note: The transmitter is automatically activated when it detects activity from the user's heart. Additionally, it automatically deactivates when it does not receive any activity. Although the transmitter is water resistant, moisture can have the effect of creating false signals, so you should take precautions to completely dry the transmitter after use to prolong battery life (estimated transmitter battery life is 2500 hours). The replacement battery is Panasonic CR2032.

ERRATIC OPERATION

Caution! Do not use this treadmill for Heart Rate unless a steady, solid Actual Heart Rate value is being displayed. High, wild, random numbers being displayed indicate a problem.

Areas to look for interference which may cause erratic heart rate:

1. Microwave ovens, TV's, small appliances, etc.
2. Fluorescent lights.
3. Some household security systems.
4. Perimeter fence for a pet.
5. Some people have problems with the transmitter picking up a signal from their skin. If you have problems, try wearing the transmitter upside down. Normally the transmitter will be oriented, so the SOLE logo is right side up.
6. The antenna that picks up your heart rate is very sensitive. If there is an outside noise source, turning the whole machine 90 degrees may de-tune the interference.
7. Loose treadmill console or bolts in the upright tube.
8. Another Individual wearing a transmitter within 3' of your machine's console.

If you continue to experience problems, contact your dealer.

WARNING! - DO NOT USE THE HEART RATE PROGRAM IF YOUR HEART RATE IS NOT REGISTERING PROPERLY ON THE TREADMILL'S DISPLAY!

GENERAL MAINTENANCE

BELT & DECK

Your treadmill uses a very high-efficient low-friction deck. Performance is maximized when the deck is kept as clean as possible. Use a soft, damp cloth, or paper towel, wipe the edge of the belt and the area between the belt edge and the frame. Also, reach as far as practical directly under the belt edge. This should be done once a month to extend belt and bed life. A mild soap and water solution along with a nylon scrub brush will clean the top of the textured belt. **Allow to dry before using.**

BELT DUST

This occurs during normal break-ins or until the belt stabilizes. Sometimes the black dust from the belt will appear on the floor behind the treadmill, this is normal.

GENERAL CLEANING (Use the chart on Pg. 7 to record your maintenance)

Dirt, dust, and hair can block air inlets and accumulate on the running belt. Please vacuum underneath your treadmill on a monthly basis to prevent excess build-up of dirt that can get sucked up and get into the inner workings under the motor cover. Every other month, you should remove the motor cover and carefully vacuum out dirt and hair that may accumulate. **UNPLUG THE POWER CORD BEFORE THIS TASK.**

BELT ADJUSTMENTS

Tread-belt Tension Adjustment - Belt tension is not critical for most users. It is very important though for joggers and runners in order to provide a smooth, steady running surface. Adjustment must be made from the rear roller with the M6 L Allen wrench (**132**) provided in the parts package. The adjustment bolts are located at the end of the step rails as shown in the diagram below. **Note:** *Adjustment is through small hole in end cap.*

Tighten the rear roller only enough to prevent slippage at the front roller. Turn the tread-belt tension adjusting bolts 1/4 turn each and inspect for proper tension by walking on the belt and making sure it is not slipping or hesitating with each step. When an adjustment is made to the belt tension, you must be sure to turn the bolts on both sides evenly or the belt could start tracking to one side instead of running in the middle of the deck.

DO NOT OVERTIGHTEN – Over tightening will cause belt damage and premature bearing failure. If you tighten the belt a lot and it still slips, the problem could actually be the drive belt - located under the motor cover - that connects the motor to the front roller. If that belt is loose it feels similar to the walking belt being loose. Tightening the motor belt should be done by a trained service person.

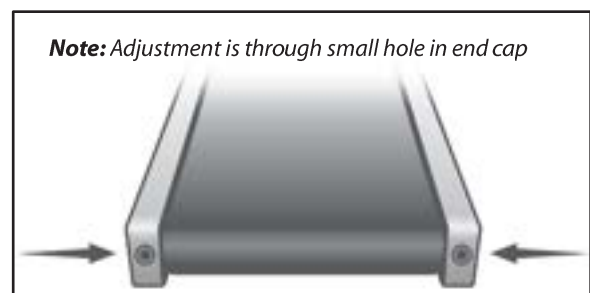

TREAD-BELT TRACKING ADJUSTMENT

The treadmill is designed so that the tread-belt remains reasonably centered while in use. It is normal for some belts to drift near one side while in use, depending on a user's gait and if they favor one leg. But if during use the belt continues to move toward one side, adjustments are necessary.

TO SET TREAD-BELT TRACKING

A 6 mm Allen wrench (**132**) is provided for this adjustment. Make tracking adjustments on the left side bolt. Set belt speed at 3 mph. Be aware that a small adjustment can make a dramatic difference which may not be apparent right away. If the belt is **too close to the left side**, then turn the bolt only a 1/4 turn to the right (clockwise) and wait a few minutes for the belt to adjust itself.

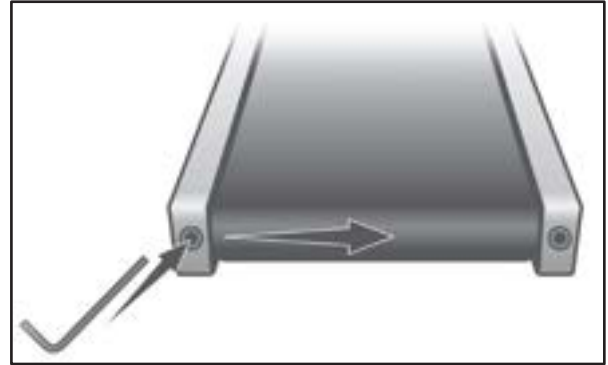

Continue to make 1/4 turn until the belt stabilizes in the center of the running deck.

If the belt is **too close to the right side**, turn the bolt counterclockwise. The belt may require periodic tracking adjustment depending on use and walking/running characteristics. Some users may affect tracking differently. Expect to make adjustments as required to center the tread-belt. Adjustments will become less of a maintenance concern as the belt is used. Proper belt tracking is an owner responsibility common with all treadmills.

ATTENTION:

DAMAGE TO THE RUNNING BELT RESULTING FROM IMPROPER TRACKING / TENSION ADJUSTMENTS IS NOT COVERED UNDER THE SOLE WARRANTY.

BELT/DECK LUBRICATION

First, you want to clean between the belt and deck to remove any debris that may be trapped. Use a clean, non-fraying rag, t-shirt, or light towel. Halfway between the end of the treadmill and motor cover, shove the garment under the belt until you can grasp it on both sides of the belt. Drag the garment the length of the entire belt 1-2 times. Remove the garment.

Do not lubricate with anything other than Sole Fitness approved lubricant. Your treadmill comes with one tube of "Lube" and extra tubes can be ordered directly from Sole Fitness or your authorized Sole Fitness dealer. You may also use a Lube-n-Walk kit that can be purchased through both aforementioned sellers.

Keeping the deck lubricated at the recommended intervals ensures the longest life possible for your treadmill. If the lubricant dries out, the friction between the belt and deck rises and places undue stress on the drive motor, drive belt and electronic motor control board, which could result in catastrophic failure of these expensive components. Failure to lubricate the deck at regular intervals may void the warranty.

The belt & deck come pre-lubricated and subsequent lubrication should be performed every 90 hours of use or if you notice that the deck is dry. It is recommended that you reach between the belt and deck to verify there is lubrication present, every other month. If you check and there isn't any lubrication present, follow the procedure below even though the "Lube" indicator isn't lit on the console. Otherwise, lubricate when the console's lubrication reminder lights after 90 hours of use. Use the following procedure to apply the silicone lubricant:

1. Turn the power switch off and unplug the power cord from the wall outlet
2. Measure 18" from the edge of the motor cover; kneel down and reach under the belt approximately 4- 6" from one edge. Squirt a line of lubricant about 1/8" wide x 15" long in an "S" pattern perpendicular to the motor cover.
3. Repeat the process on the opposite side.
4. Plug the electrical cord back into the outlet and turn the power switch on.
5. Walk on the belt at a moderate speed for five minutes to evenly distribute the silicone lube.
6. If the "Lube" message appears on the console, perform the following procedure to reset the message:
 - a. To enter the Engineering Mode Menu press and hold down the **Start, Stop** and **Enter** keys, then at the same time insert the **Safety Key**. Keep holding the keys down until the **Message Window** displays Engineering Mode Menu. Press the **Enter** button to access.
 - b. Press the **Speed ▲** button (or **Speed ▼** button to go backwards) until "Functions" appears; press **Enter**.
 - c. Press the **Speed ▲** button until "Maintenance" message appears; press **Enter** to reset the lube message.
 - d. Press **Stop** to exit Engineering Mode and resume use of your treadmill.

SERVICE CHECKLIST - DIAGNOSIS GUIDE

Before contacting your dealer for aid, please review the following information. It may save you both time and expense. This list includes common problems that may not be covered under the treadmill's warranty.

PROBLEM	SOLUTION/CAUSE
Display does not light	<ol style="list-style-type: none"> 1. Tether cord not in position. 2. Circuit breaker on front grill tripped. Push circuit breaker in until it locks. 3. Plug is disconnected. Make sure plug is firmly pushed into AC household wall outlet. 4. Household circuit breaker may be tripped. 5. Treadmill defect. Contact your SOLE dealer.
Tread-belt does not stay centered Treadmill belt hesitates when walked/run on	<p>The user may be walking while favoring or putting more weight on either the left or right foot. If this walking pattern is natural, track the belt slightly off-center to the side opposite from the belt movement. See General Maintenance section on Tread-belt Tension. Adjust as necessary.</p>
Motor is not responsive after pressing Start	<ol style="list-style-type: none"> 1. If the belt moves, but stops after a short time and the display shows "E1", run calibration. 2. If you press Start and the belt never moves, then the display shows "E1", contact service.
Treadmill will only achieve approximately 7 mph but shows higher speed on display	<p>This indicates motor should be receiving power to operate. Low AC voltage to treadmill. Do not use an extension cord. If an extension cord is required it should be as short as possible and heavy duty 16 gauge minimum. Low household voltage. Contact an electrician or your SOLE dealer. A minimum of 110 volt AC current is required.</p>
Tread-belt stops quickly/suddenly when tether cord is pulled	<p>High belt/deck friction. See General Maintenance section on lubrication.</p>
Treadmill trips on board 15 amp circuit	<p>High belt/deck friction. See General Maintenance</p>
Computer shuts off when console is touched (on a cold day) while walking/running	<p>Treadmill may not be grounded. Static electricity is "crashing" the computer. Refer to Grounding Instructions on page 3.</p>
House circuit breaker trips, but not the treadmill circuit breaker	<p>Check that the treadmill is the only appliance in the circuit. See "Important Electrical Information" in the front of this manual for more details.</p>

CALIBRATION PROCEDURE

1. Remove the **Safety Key**.
2. Press and hold down the **Start** and **Speed ▲** buttons and at the same time replace the **Safety Key**. Continue to hold the **Start** and **Speed ▲** keys until the window displays “Factory settings”, then press the **Enter** key.
3. You will now be able to set the display to show Metric or English settings (Miles vs. Kilometers). To do this, press the **incline▲/▼** key to show which you want, then press **Enter**. (The maximum speed value is displayed in the speed window, and the maximum elevation value is displayed in the incline window.)
4. Grade return – On (This allows the incline to return to zero when **Stop** button is pressed. For sale in Europe, EU standards require this to be off)
5. Press **Start** button to begin calibration. The process is automatic; the speed will start up without warning, so do not stand on the belt.

ADJUSTING THE SPEED SENSOR

If the calibration does not pass you may need to check the speed sensor alignment.

1. Remove the motor cover hood by loosening the 4 screws that hold it in place (you do not need to remove them completely).
2. The speed sensor is located on the left side of the frame, right next to the front roller pulley (the pulley will have a belt around it that also goes to the motor). The speed sensor is small and black with a wire connected to it.
3. Make sure the sensor is as close as possible to the pulley without touching it. You will see a magnet on the face of the pulley; make sure the sensor is aligned with the magnet. There is a screw that holds the sensor in place that needs to be loosened to adjust the sensor. Re-tighten the screw when finished.



MAINTENANCE MENU

1. Press and hold the **Start**, **Stop** and **Enter** key at the same time, until the display shows “Engineering mode” (it may say maintenance menu, depending on version). Press the **Enter** key.
2. You can now scroll through the menu using the **Speed ▲/▼** keys. Use the **Stop** key to return to previous menu selection. The menu selections are:
 - A. **Key Test** - Will allow you to test all the keys to make sure they are functioning
 - B. **Display Test** - Tests all the display functions
 - C. **Functions** - Press **Enter** to access settings, use **Speed ▲/▼** keys to scroll
 - I. **Sleep Mode** - Turn on to have the console power down automatically after 15 minutes of inactivity
 - II. **Pause Mode** - Turned on to allow 5 minutes of pause, turn off to have console pause in definitely
 - III. **Maintenance** - Reset lube message and odometer readings
 - IV. **Units** - Choose from English or Metric display readings
 - V. **Key Tone** - Will turn on/off beeping noise that is made when keys are pressed.
 - D. **Security** - Allows you to lock the keypad so no unauthorized use of the machine is allowed. When the child lock is enabled, the console will not allow the keypad to operate unless you press and hold the **Start** and **Enter** buttons for 3 seconds to unlock the console.
 - E. **Exit**

EXPLODED VIEW DIAGRAM

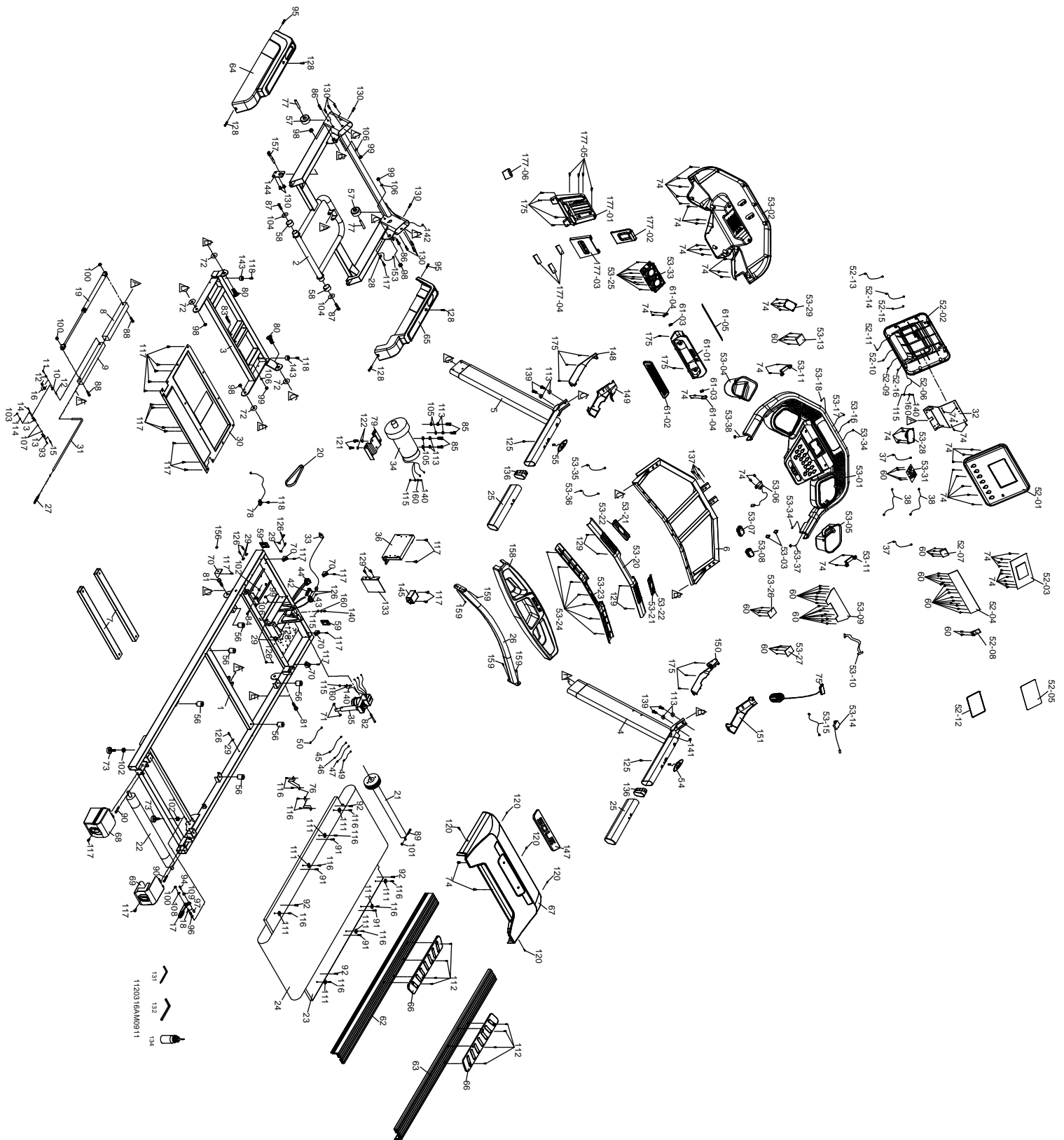

PARTS LIST

Key	Part	Part Description	Q'ty
1	AA010284-Q2	Main Frame	1
2	CRAA020119-Q2	Frame Base	1
3	AA030082-Q2	Incline Bracket	1
4	CRAA040274-Q2	Right Upright	1
5	CRAA040277-Q2	Left Upright	1
6	CRAA050142-Q2	Console Support	1
7	A440427-Q2	Deck Cross Brace	2
8	AA060001-Q2	Outer Slide	1
9	AA060067-Z2	Inner Slide	1
10	B020001-Z1	Link	1
11	C010003-Z1	Link Shaft	1
12	C070025-Z1	Shaft Bushing	2
13	B020002-Z1	Fastening Bracket	2
14	C040005-Z1	Clevis Pin	1
15	C070026-Z1	Fastening Bushing	1
16	K010001	Dual Torsion-Spring	1
17	P060219-A7	Release Lever	1
18	K010002-Z1	ChenChin Torsion-Spring	1
19	K060017	Cylinder	1
20	N010001	Drive Belt	1
21	K140100-Z9	Front Roller W/Pulley	1
22	K140101-Z3	Rear Roller	1
23	H140051	Running Deck	1
24	H0713240H-RY	Running Belt	1
25	L030032-A1	PVC Handgrip	2
26	AA060232-Q2	Handrail Support	1
27	K010003	Steel Cable Tension Spring	1
28	N050002	Wire Clamp	1
29	P060281	Wire Tie Mount	8
30	P090134-A1	Motor Bottom Cover	1
31	K020003	Steel Cable	1
32	AA060229-Q2	Welding Support	1
33	E060001	Power Cord	1
34	CRG080603B	Drive Motor	1
35	G150004	Incline Motor	1
36	CRD020109-04	Motor Controller	1
37	E060501D	400m/m Amplifier Cable	2
38	E070404	400m/m Audio Bluetooth Signal Wire	2
42	F020019	Breaker	1
43	F010007	Power Socket	1
44	F030008	AC Electronic Module	1
45	E010747	100m/m Connecting Wire (Black)	1
46	E010754	300m/m Connecting Wire (White)	1
47	E010755	300m/m Connecting Wire (Black)	1

Key	Part	Part Description	Q'ty
49	E010752-01	200m/m Connecting Wire (White)	1
50	E010753-01	200m/m Connecting Wire (Black)	1
51	CRZ4YT0690-20	Console Assembly	1
52	CRZ4P020621B-A1-01	Console Assembly(Top)	1
53	CRZ4P020632-JQ-01	Console Assembly(Bottom)	1
54	N110007A	Speed Adjustment Switch W/Cable	1
55	N110002A	Incline Adjustment Switch W/Cable	1
56	P060550-A1	Cushion	6
57	P050002-A1	Transportation Wheel(A)	2
58	P050007-A1	Transportation Wheel(B)	2
59	P040002-A1	Square End Cap	2
60	J527201-ZF	2.3 × 6m/m Sheet Metal Screw	51
61	CZP020618-KQ	Fan Plate Assembly	1
62	P080075A-A1	Foot Rail(L)	1
63	P080075B-A1	Foot Rail(R)	1
64	P140073B-A1	Frame Base Cover (L)	1
65	P140074B-A1	Frame Base Cover (R)	1
66	P130047B-A1	Pedal	2
67	CRP010165-A1	Motor Top Cover	1
68	P030136-A1	Adjustment Base (L)	1
69	P030137-A1	Adjustment Base (R)	1
70	P060181-A1	Motor Cover Anchor	5
71	P060221-A1	Nylon Washer (A)	2
72	P060801-A1	Nylon Washer (B)	4
73	CRP060018-A1	Adjustment Foot Pad	2
74/177-05	J396804-Y3	3.5 × 12m/m Sheet Metal Screw	60
75	N100028-A5	Trapezoidal Safety Key	1
76	B133000-Z1	Belt Guide	2
77	C070031-Z4	Wheel Sleeve	2
78	F030191	Sensor W/Cable	1
79	B134029-Y3	Motor Bracket	1
80	J071504-Y3	1/2" × UNC12 × 1-1/4" Carriage Bolt	2
81	J011503-Y3	1/2" × 1" Hex Head Bolt	2
82	J031018G-ZS	3/8" × 4-1/2" Socket Head Cap Bolt	1
83	J011015R-ZS	3/8" × 3-3/4" Hex Head Bolt	1
84	J011005-Y3	3/8" × 1-1/4" Hex Head Bolt	1
85	J011002-Y3	3/8" × 3/4" Hex Head Bolt	4
86	J341008-Y3	3/8" × UNC16 × 2" Flat Head Socket Bolt	2
87	J020504-Y3	5/16" × 1" Button Head Socket Bolt	2
88	J020511J-Y3	5/16" × 2-3/4" Button Head Socket Bolt	2
89	J013012-Y3	M8 × 60m/m Hex Head Bolt	1
90	J033016-ZS	M8 × 80m/m Socket Head Cap Bolt	2
91	J043010-Y3	M8 × 50m/m Flat Head Countersink Bolt	4
92	J043005-Y3	M8 × 25m/m Flat Head Countersink Bolt	4

Key	Part	Part Description	Q'ty
93	J354001-Y3	M3 × 10m/m Phillips Head Screw	1
94	J092004-Y3	M5 × 20m/m Phillips Head Screw	1
95	J092005-Y3	M5 × 25m/m Phillips Head Screw	2
96	J020524-Y3	5/16" × 42m/m Button Head Socket Bolt	1
97	J139161-Y3	M5 × 5T Nylon Nut	1
98	J139111-Y3	1/2" × 8T Nylon Nut	4
99	J139011-Y3	3/8" × 7T Nylon Nut	4
100	J139062-Y3	5/16" × 7T Nylon Nut	3
101	J139261-Y3	M8 × 7T Nylon Nut	1
102	J129021-Y3	3/8" × 7T Nut	3
103	J129221-Y3	M3 × 2.5T Nut	1
104	J210001-Y3	Ø5/16" × Ø35 × 1.5T Flat Washer	2
105	J210008-Y3	Ø3/8" × Ø25 × 2.0T Flat Washer	4
106	J210003-Y3	Ø3/8" × Ø19 × 1.5T Flat Washer	4
107	J210004-Y3	Ø5 × Ø10 × 1T Flat Washer	2
108	J210005-Y3	Ø5/16" × Ø18 × 1.5T Flat Washer	1
109	J210069-Y3	Ø5 × Ø13 × 1.0T Flat Washer	1
111	B130016-Z1	Ø25 × 20 × 16 × 5 × 1.1T × 4.5H Concave Washer	8
112	J397005-Y3	3 × 16m/m Sheet Metal Screw	8
113	J260004-Y3	Ø10 × 1.5T Split Washer	8
114	J260002-Y3	M3×1T Split Washer	1
115	J270001-Z1	M5 Star Washer	4
116	J386904-Y3	4 × 12m/m Sheet Metal Screw	12
117	J367105-Y3	Ø5 × 16m/m Tapping Screw	24
118	J367114-Y3	5 × 19m/m Tapping Screw	3
120	J377105-Y3	5 × 16m/m Tapping Screw	5
121	J013002-Y3	M8 × P1.25 × 12m/m Hex Head Bolt	2
122	J260007-Y3	Ø8 × 1.5T Split Washer	2
125	J526924-Y3	Ø4 × 60m/m Flat Head Socket Bolt	2
126	J536805-Y3	3.5 × 16m/m Tapping Screw	10
128	J092003-Y3	M5 × 15m/m Phillips Head Screw	4
129	J397002-Y3	3 × 8m/m Sheet Metal Screw	6
130	J020501-Y3	5/16" × 1/2" Button Head Socket Bolt	10
131	J330029-Y3	M5 Allen Wrench Head Screw Wrench	1
132	J330002-Y3	M6 L Allen Wrench	1
133	B070005-Q2	Controller Back Plate	1
134	N020007A	Lubricant	1
136	P040133-A1	Handgrip End Cap	2
137	J092006-Y3	M5 × 30m/m Phillips Head Screw	4
139	J021007-Y3	3/8" × 1-3/4" Button Head Socket Bolt	4
140	J092001-Y3	M5 × 10m/m Phillips Head Screw	4
141	E020288	1300m/m Computer Cable (Middle)	1
142	E020287-02	1200m/m Computer Cable(Lower)	1
143	P060252-A1	Rubber Foot Pad	2

Key	Part	Part Description	Q'ty
144	B020290-Q2	Locking Pin Fixing Plate	1
145	F060116	Filter	1
147	P010164-KQ	Top Motor Cover Plate	1
148	P020623-A1	Console Mast Cover Outer (L)	1
149	P020624-A1	Console Mast Cover Inner (L)	1
150	P020626-A1	Console Mast Cover Inner (R)	1
151	P020625-A1	Console Mast Cover Outer (R)	1
153	E040005	1000m/m Ground Wire	1
156	P280046-A1	End Cap	1
157	N200216	Locking Pin Assembly	1
158	P220048-A1	Beverage Holder	1
159	J020502-Y3	5/16" × 3/4" Button Head Socket Bolt	4
160	J260008-Y3	Ø5 × 1.5T Split Washer	4
175	J396805-Y3	3.5 × 16m/m Sheet Metal Screw	12
177	CRP240029-A1	Tablet Holder	1

MANUFACTURER'S LIMITED WARRANTY

TREADMILL WARRANTY

Dyaco Canada Inc. warrants all its Sole treadmills' parts, for a period of time listed below, from the date of retail sale, as determined by sale receipt. Dyaco Canada Inc.'s responsibilities include providing new or remanufactured parts, at Dyaco Canada Inc.'s option, and technical support to our independent dealers and servicing organizations. In the absence of a dealer or service organization, these warranties will be administered by Dyaco Canada Inc. directly to a consumer. The warranty period applies to the following components:

Frame Weldments	Lifetime
Drive Motor	Lifetime
Deck	2 Years
All Other Components	2 Years
Labor	1 Year
Cosmetic Items *	90 Days

*Cosmetic items including, but not limited to the following: grips, console overlays, and labels/decals.

NORMAL RESPONSIBILITIES OF THE CONSUMER

This warranty applies only to products in ordinary household use, and the consumer is responsible for the items listed below:

1. The warranty registration can be completed online: Go to www.dyaco.ca/warranty and complete the online warranty registration.
2. Proper use of the treadmill in accordance with the instructions provided in this manual, including belt tracking.
3. Proper installation in accordance with instructions provided with the treadmill and with all local electric codes.
4. Proper connection to a grounded power supply of sufficient voltage, replacement of blown fuses, repair of loose connections or defects in house wiring.
5. Expenses for making the treadmill accessible for servicing, including any item that was not part of the treadmill at the time it was shipped from the factory.
6. Damages to the treadmill finish during shipping, installation or following installation.
7. Routine maintenance of this unit as specified in this manual.

EXCLUSIONS

This warranty does not cover the following:

1. CONSEQUENTIAL, COLLATERAL, OR INCIDENTAL DAMAGES SUCH AS PROPERTY DAMAGE AND INCIDENTAL EXPENSES RESULTING FROM ANY BREACH OF THIS WRITTEN OR ANY IMPLIED WARRANTY.

Note: Some areas do not allow the exclusion or limitation of incidental or consequential damages, so this limitation or exclusion may not apply to you.

2. Service call reimbursement to the consumer. Service call reimbursement to the dealer that does not involve malfunction or defects in workmanship or material, for units that are beyond the warranty period, for units that are beyond the service call reimbursement period, for treadmill not requiring component replacement, or treadmill not in ordinary household use.
3. Damages caused by services performed by persons other than authorized Dyaco Canada Inc. service companies; use of parts other than original Dyaco Canada Inc. parts; or external causes such as corrosion, discoloration of paint or plastic, alterations, modifications, abuse, misuse, accident, improper maintenance, inadequate power supply, or acts of God.
4. Products with original serial numbers that have been removed or altered.
5. Products that have been: sold, transferred, bartered, or given to a third party.
6. Products that do not have a warranty registration card on file at Dyaco Canada Inc. Dyaco Canada Inc. reserves the right to request proof of purchase if no warranty record exists for the product.
7. THIS WARRANTY IS EXPRESSLY IN LIEU OF ALL OTHER WARRANTIES EXPRESSED OR IMPLIED, INCLUDING THE WARRANTIES OF MERCHANTABILITY AND/OR FITNESS FOR A PARTICULAR PURPOSE.
8. Product use in any environment other than a residential setting.
9. Warranties outside of North America may vary. Please contact your local dealer for details.

SERVICE

Keep your bill of sale. The labour period is twenty-four (24) months from the date on the bill of sale. If service is performed, it is in your best interest to obtain and keep all receipts. This written warranty gives you specific legal rights. You may also have other rights that vary in different areas. Service under this warranty must be obtained by following these steps, in order:

1. Contact your selling authorized SOLE dealer.
2. If you have any questions about your new product or questions about the warranty contact Dyaco Canada Inc. at 1-888-707-1880.
3. If no local service is available, Dyaco Canada Inc. will repair the parts, at Dyaco Canada Inc.'s option, within the warranty period at no charge for parts. All transportation costs, both to our factory and upon return to the owner, are the responsibility of the owner. The owner is responsible for adequate packaging upon return to Dyaco Canada Inc. Dyaco Canada Inc. is not responsible for damages that occur during shipping. Make all freight damage claims with the appropriate freight carrier. DO NOT SHIP ANY UNIT TO OUR FACTORY WITHOUT A RETURN AUTHORIZATION NUMBER. All units arriving without a return authorization number will be refused.
4. For any further information, or to contact our service department by mail, send your correspondence to:

Dyaco Canada Inc.
5955 Don Murie Street
Niagara Falls, ON
L2G 0A9

Product features or specifications as described or illustrated are subject to change without notice. All warranties are made by Dyaco Canada Inc.

dyaco

Please visit us online for information about our other brands and products, manufactured and distributed by Dyaco Canada Inc.

SPIRIT

spiritfitness.ca

XTEERRA

xterrafitness.ca

UFC

dyaco.ca/UFC/UFC-home.html

SOLE
FITNESS

solefitness.ca

EVERLAST

dyaco.ca/products/everlast.html

Johnny G
by SPIRIT

spiritfitness.ca/johnnyg.html

TRINOR
SPORTS

trainorsports.ca

For more information, please contact Dyaco Canada Inc.
T: 1-888-707-1880 | 5955 Don Murie St., Niagara Falls, Ontario L2G 0A9 | sales@dyaco.ca

SOLE
FITNESS